

AVIATION

Refueler Tankers

Length:	10 330mm (carrier dependant).
Width:	2 560mm
Height:	3550 (Typical).
Tare Weight:	As per technical specification.
Freight Carrier:	As per client specification.



TANK DESIGN

Design Types:	Rigid
Design Capacity:	4 000l, 8 000l, 13 000l & 19 000l.
Baffles:	One or two capacity pending.
Compartments:	One
Shape:	Elliptical with tapered elliptical end sections.
Approval:	EN 12312-5, ADR (latest) & SANS 1518 (latest).

TANK CONSTRUCTION

Tank Shell:	Aluminium 5182H111 / XTral 728 5mm thickness.
Tank Dishes:	Aluminium 5182H111 / XTral 728 5.2mm thickness.
Construction:	Banded construction with aluminium T section stiffeners.
Overturn Protection:	Extruded valance welded to tank top with transverse members.
Tank Mounting:	Two or four point fixing rubber mounted to chassis. Trunnion option design pending.
Side Protection:	Extruded dual under-run aluminium profiles along unprotected sections on both sides with curved front corners.

TANK FITTINGS

Manlids:	Emco Wheaton 500mm manlid with 250mm hinged filling lid fitted on a 600mm diameter neckring. Pressure Vacuum roll-over breather fitted in manhole lid.
Sensors and Vents:	Alfons Haar sequential vents with fire gauze. Whittaker primary overfill sensor incorporated with bottom loading configuration. Secondary overfill Alfons Haar / Niehuser.
Vapour Recovery:	Individually recovered through valance.
Content Gauge:	150mm or 250mm Bayham.

ELECTRICAL SYSTEM

Wiring Harness:	24V System to legal specification – fully SABS approved.
Lights:	Dual LED stop/tail and direction indicators on either side. Additional high level LED stop/tail lamp per side. One LED reverse lamp per side.
High Level Lights:	Additional high level LED stop/tail lamp per side.
Reverse Light:	One LED reverse lamp per side.
Reverse Alarm:	87db reverse alarm.
Working Lights:	Working lights are fitted accordingly to specification.
Beacon Light:	A LED beacon light is fitted on cab.
Interlock System:	Amber LED interlock warning light is fitted inside cab for each interlock with red interlock override LED light.

BOTTOM EQUIPMENT

Filling:	Whittaker system with 4" internal Foot valve and pre-check valve integrated into primary overfill system.
Bottom Discharge:	3" Fulcrum pneumatically operated footvalve operating from main control panel.
Sample Drain:	1.5" Apollo spring leaded return ball valves for sample with camlock and cap. Pilot product sampling is routed through a closed circuit sampler to 50 litre dumptank. Pressure relieve system is installed to limit pressure on 1.2" bar when the trailer is not operating. Pressure return line is routed back into tank.
Return Line:	Pressure relieve system is installed to limit pressure on 1.2" bar when the trailer is not operating. Pressure return line is routed back into tank.
Filter Vessel:	Velcon/VFP vessel fitted with Velcon filters as per specification.
Flow Meter:	3" Avery hardoll meter or 3" LC meter.
Hose Reel:	Overwing and underwing Alfons Haar hydraulically driven fitted with flexible hoses.

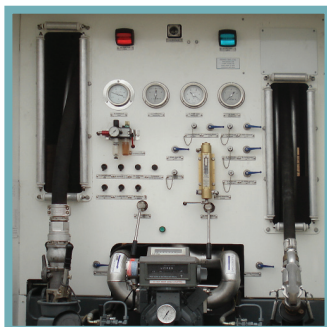

ENGINEERING & SERVICE EXCELLENCE

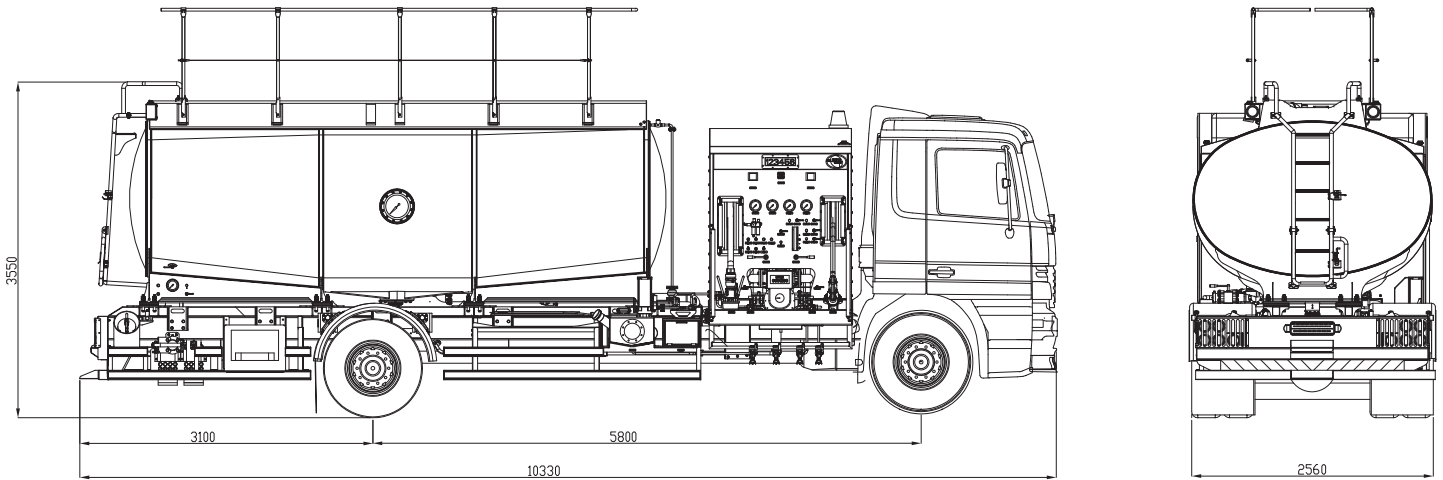

PRODUCT PUMP

Type: 3" Gorman Rupp or 2' Alfons Haar hydraulic driven from PTO.

EQUIPMENT

- Cabinet: Stainless steel cabinet housing hose reel, instrument panel and operating equipment. Roller door fitted as option.
- Spare Wheel Carrier: Single wheel winch type.
- Fire Extinguishers: Open holder with 9kg extinguisher per side.
- Toolbox: Lockable plastic moulded box.
- Wheel Chocks: Plastic moulded chocks with retaining cables.
- Ladder: Aluminium ladder fitted to the rear of tanker.
- Handrail: Aluminium dual placement.
- Earthing Equipment: Reeled 15m coated stainless steel cable with clamp fitted near side. Brass bonding lugs fitted near side.
- Walkway: Black safety anti-slip strips bonded to tank top.
- Drive Away Prevention: Interlocks fitted to all inlets and outlets.

PAINT & FINISH

- Interior Finish: Etched only.
- Exterior Finish: Painted to customer specification.
- Decals: Mandatory safety decals applied.
Option: Customer livery to specification.

WARRANTY

Warranty: Twelve month warranty period subject to the standard conditions of sale and repair.
Option: Five year extended warranty.



GRW Engineering (Pty) Ltd.

20 Abattoir Road
Worcester, 6850
P.O. Box 5102
Worcester, 6849

Tel: +27 (0)23 348 6300
Fax: +27 (0)23 348 6348
Fax: +27 (0)23 347 3895

email: grw@grw.co.za
web site: www.grw.co.za