

DRY BULK PNEUMATIC

Aluminium Tankers

Length:	12 900mm	
Width:	2 600mm	
Height:	4 000mm	
Coupling Height:	1 320mm	
Ride Height:	420mm	
Wheelbase:	10 000mm	
Tare Weight:	As per technical specification – product range specific.	
Payload:	40m ³	30 000 – 33 000kg
	49m ²	30 000 – 33 000kg
	49m ³ + 14m ³	30 000 + 6 500kg



TANK DESIGN

Design Types:	Tridem semi, tridem semi and tandem pup combination.
Design Capacity:	Product and design specific.
Baffles:	One
Compartments:	One
Shape:	Design specific.
Approval:	AD Merkblatter

TANK CONSTRUCTION

Tank Shell:	Aluminium
Cradle Construction:	Aluminium
Chassis:	Aluminium
Landing Legs:	Jost D200A with swivel round feet, 2-speed gearbox and crank handle operating both supports simultaneously.
Rubbing plate:	12mm grade 50B steel with Jost 50mm flanged kingpin.
Rear Bumper:	Aluminium extruded section bolted to removable aluminium supports.

RUNNING GEAR

Suspension:	BPW ALM air suspension.
Axles:	BPW EcoPlus 9 tonne 120mm square beam.
Track Width:	2140mm track.
Brakes:	Drum brakes 420 x 180mm with automatic slack adjusters.
Lifting axle:	Option: Front axle only.
Steering axle:	Option: Rear self-steering with stabiliser.
Tyres:	385/65 R22. Single.
Rims:	Aluminium or mild steel.
Hubodometer:	BPW electronic fitted near side centre axle.

BRAKE SYSTEM

EBS System:	Wabco 4S/2M EBS system.
Air tanks:	Mild steel with manual or automatic drain valves.
Couplings:	Seven pin ISO 12098 female plug for EBS power.

ELECTRICAL SYSTEM

Wiring Harness:	Sealed harness and connectors.
Lights:	LED type individually mounted two per side – tail/brake/indicator with separate reverse light.
Fog Light:	LED type mounted to rear.
Marker Lights:	To the side and front, rear rubber stork lights fitted to tail board.
Reverse Alarm:	87db reverse alarm.
Coupling:	7 Pin female trailer plug. Fifteen pin ISO female plug as well as 7 pin caravan type female plug.

TANK TOP FITTINGS

Loading Hatches:	Bolt down manlids manually or pneumatically operated.
------------------	---



ENGINEERING & SERVICE EXCELLENCE

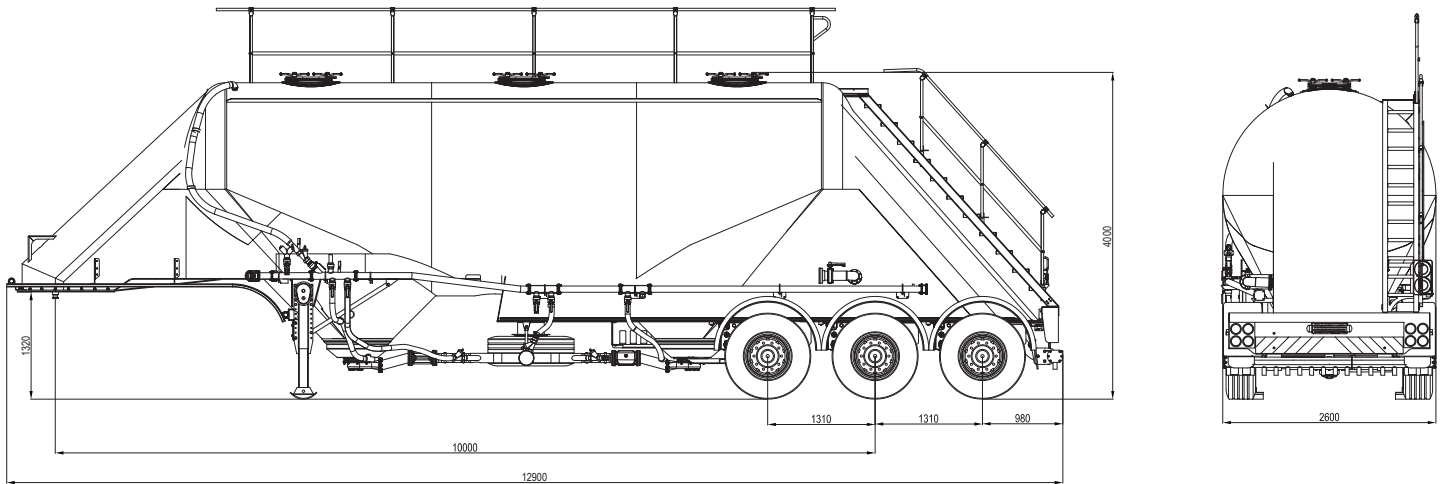

BOTTOM DISCHARGE EQUIPMENT

- Tank Outlets:** Discharge cones fitted with 800mm synthetic aeration pads.
- Bt. Discharge Valves:** One pneumatic bottom outlet valve fitted to each discharge cone.
- Tank Discharge Line:** Single 100mm mild steel discharge line from each discharge cone running into one discharge line terminating with a 100mm Storz coupling c/w cap preceded by a ring-jet accelerator valve.
- Ld. couplings & Flanges:** Top loading only.
- Line Valve:** One pneumatic pinch valve per discharge line.
- Spreader Bar:** Pipe work is "T" off from the discharge line on the LHS. A fixed 4" pipe or flexible hose is routed to the spreader bar at rear on the LHS of the tanker. 4" Ratchet butterfly valve for manual operation control, runs down to a multiple discharge pipe at the rear of tanker.

EQUIPMENT

- Mudguards:** BPW plastic – single. Front stainless steel.
- Spare Wheel Carrier:** Dual or single wheel winch type.
- Fire Extinguishers:** Plastic moulded holders with 9kg extinguisher per side.
- Toolbox:** Lockable plastic moulded box.
- Wheel Chocks:** Plastic moulded chocks with retaining cables.
- Ladder:** Aluminium fitted to the rear of tanker.
- Handrail:** Aluminium handrail.
- Walkway:** Aluminium walkway.
- Pressure Station:** Layout and equipment fitted is product specific. To be confirmed at time of enquiry.
- Hose Trays:** Manufactured aluminium or plastic hose tubes.
- Hoses:** Two 5m rubber hoses complete with 4" Storz couplings on both sides.

DISCHARGE COMPRESSOR

- Compressor Options:** GHH or Gardner Denver screw compressor.

PAINT & FINISH

- Exterior Finish:** Painted or natural aluminium.
Option: Painted to customer specification.
- Interior Finish:** Clean.
- Decals:** Mandatory safety decals applied.
Option: Customer livery to specification.

WARRANTY

- Warranty:** Twelve month warranty period subject to the standard conditions of sale and repair.
Option: Three year extended warranty.
- Maintenance Contract:** Optional with extended warranty. Contact sales for further details.



GRW Engineering (Pty) Ltd.

20 Abattoir Road
Worcester, 6850
P.O. Box 5102
Worcester, 6849

Tel: +27 (0)23 348 6300
Fax: +27 (0)23 348 6348
Fax: +27 (0)23 347 3895

email: grw@grw.co.za
web site: www.grw.co.za